

# Mounting Instruction

## Plug S150 + RG11

- 1) Prepare the cable

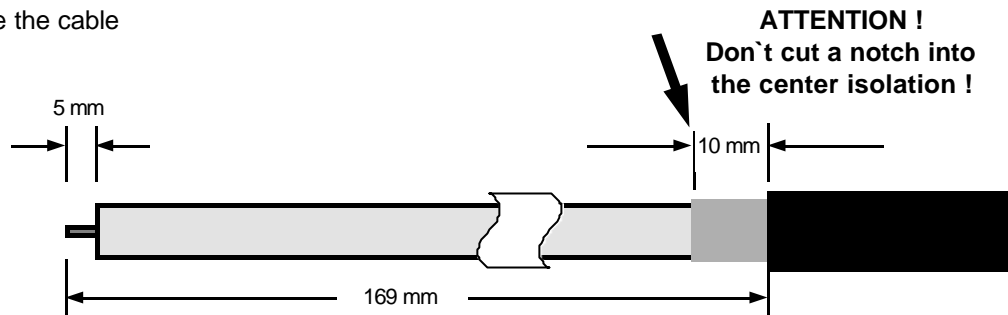

- 2) Solder the center conductor

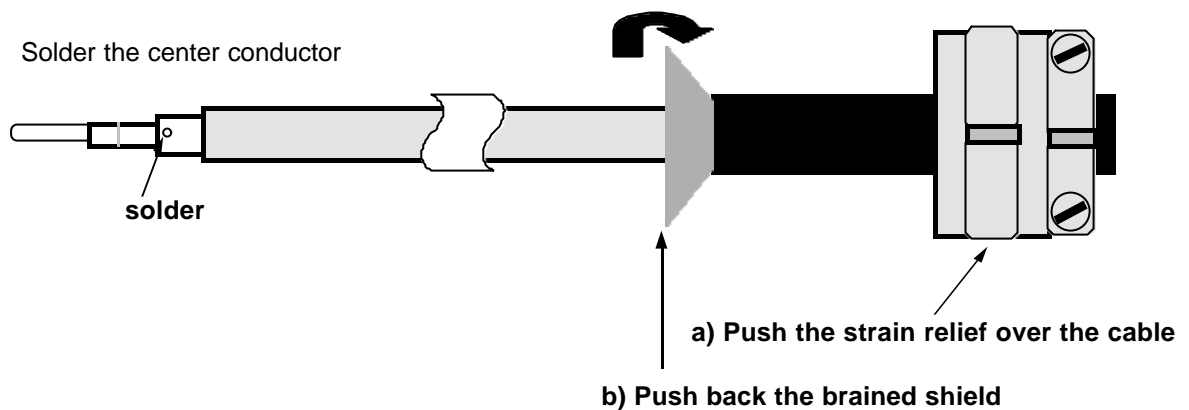

- 3) Push together
- Push the connector parts together as follows

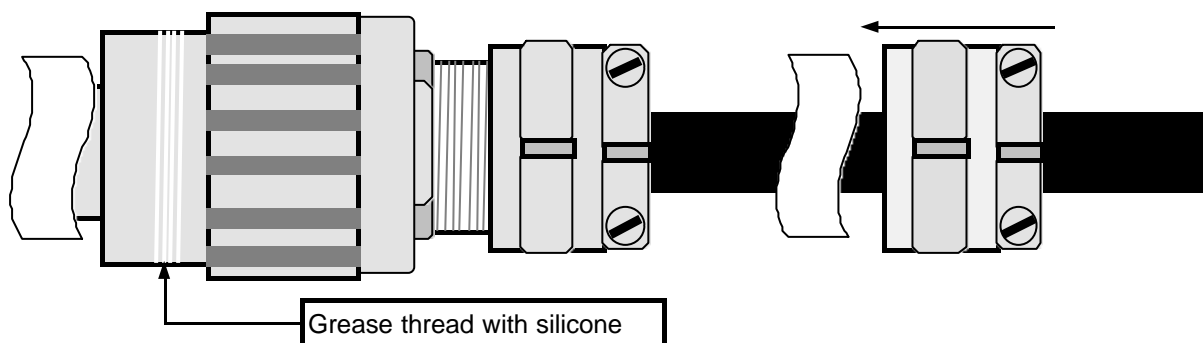
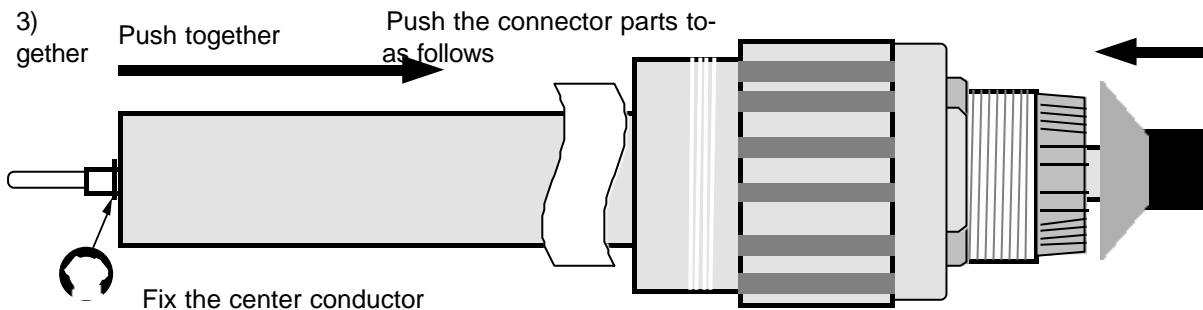

This mounting instruction is logical also valid for connectors of the same construction e.g. HVS 65. The difference is only the length of the plug and the cable diameter.

**Informations for the needed space on  
the rear side of the unit.  
Connector S150 + cable RG11**

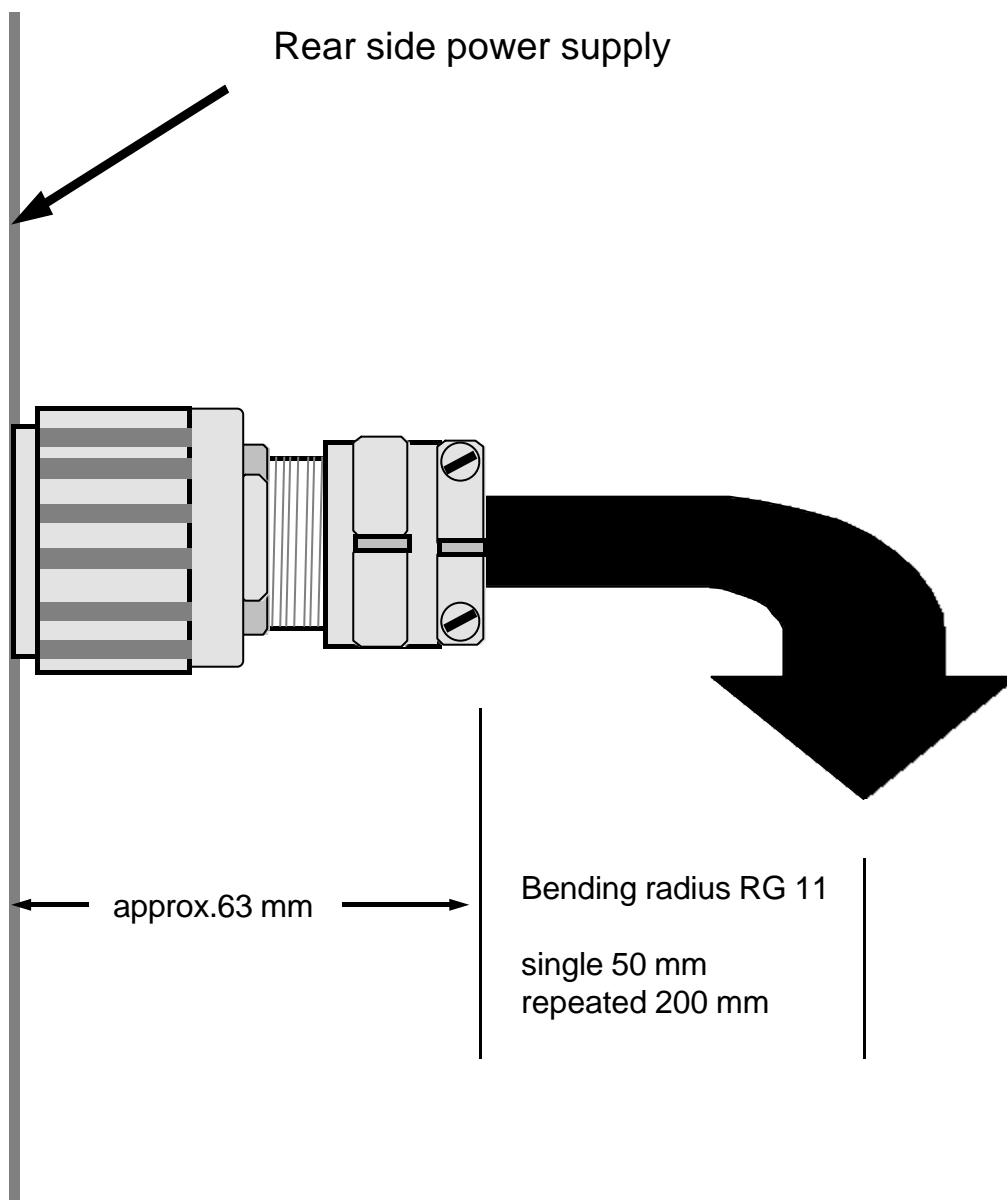

Bending radius other cables	single	repeated
C 2124	150 mm	approx. x 4
C 2121	220 mm	approx. x 4